

# EULSPILL

Lawrence Technological University

**Anthony Knapp, Nathan Koenig, Alex Lessnau, Vincent Nicolazzo,**

**Kristin Jordan, Mark Kenney, Logan Dewan, Joey Yudasz,**

**Chris Leclerc, Charles Morton, Luiz Rodriguez, Adam Drotar**

**Advised By: Professor James Kerns**

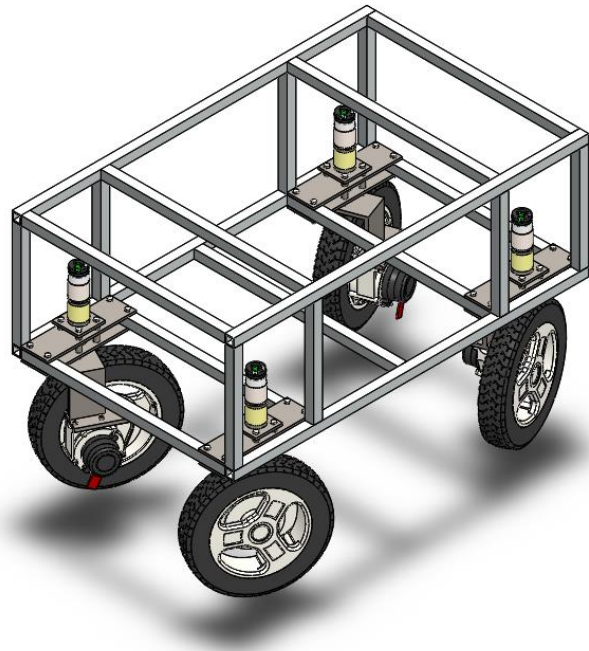

**Figure 1: CAD Drawing of EulSpill**

## INTRODUCTION

EulSpill is the Lawrence Technological University's Blue Devil Robotics Team's second year entry in IGVC. EulSpill is the culmination of the experiences from last year's competition and this year's innovations. The all-aluminum chassis was designed with weight savings and stability in mind. Additionally, the aluminum's physical properties do not allow it to affect sensors like steel. The new wheel brackets and steering motors enable each wheel to pivot independently giving EulSpill dynamic capabilities in terms of driving systems. EulSpill utilizes LIDAR, GPS and two webcams to successfully identify obstacles, lines and GPS waypoints. All software is written in C# utilizing Emgu CV, a cross platform .Net wrapper to the OpenCV image processing library.

## DESIGN PROCESS

The team followed a design process similar to that of the V-Model Design Process commonly found in industry software engineering projects. What sets this team's design process apart from others' is that it was used to design all three main systems of the robot – mechanical, electrical and software. This larger project scope made it more so important to follow a strict design process.

The team began by identifying the requirements set by the Official IGVC Rules. With a set of requirements determined, the team could begin analyzing an approach to solving the problem at hand. With the problem identified, how to create a robotic system capable of obstacle avoidance, lane following and GPS waypoint navigation, the team was able to begin design at a large scope. This large scope design consisted of multiple brainstorming sessions leading to individual team design meetings. Each team then conducted all necessary testing and research to determine a final subgroup design. Once each subgroup design was finalized, the individual designs could be integrated into the complete system. From there, all final testing was performed as necessary.

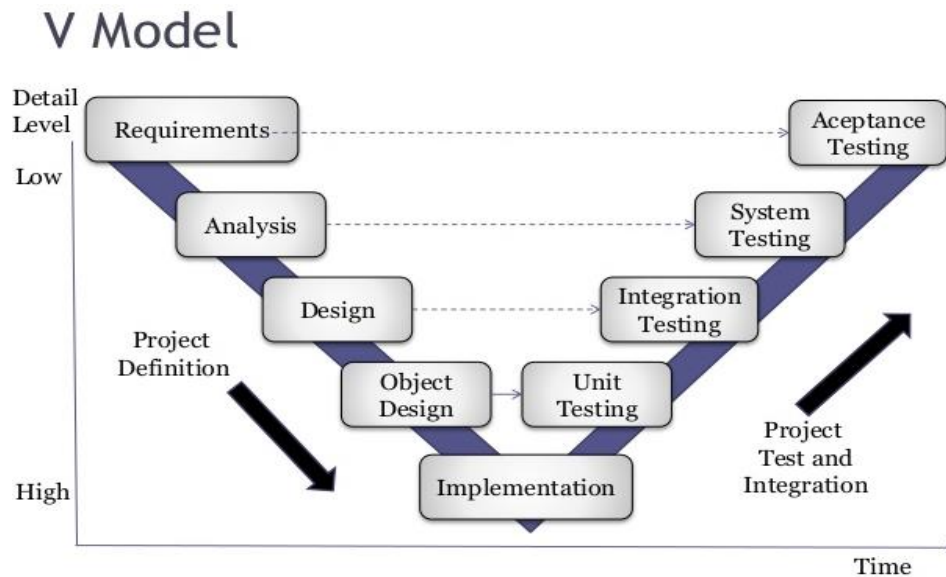

Figure 2: Example of V-Model Design

## TEAM COMPOSITION

It is important to note the team composition, as shown in Table 1. This is important because the Blue Devil Robotics Team is composed of Robotics Engineering (BSRE) students, four of which have used the IGVC project as their Senior Capstone Project as corroborated by Professor James Kerns' letter.

**Table 1. Team Composition Chart**

<b>Team Member</b>	<b>Major</b>	<b>Mechanical Design</b>	<b>Mechanical Fabrication</b>	<b>Electrical</b>	<b>Software</b>	<b>Time (hrs.)</b>
Anthony Knapp	BSRE	X	X			600
Nathan Koenig	BSRE	X	X			150
Alex Lessnau	BSRE	X	X	X		600
Vince Nicolazzo	BSRE	X	X		X	600
Logan Dewan	BSME	X	X			100
Kristin Jordan	BSRE/BSCE			X		5
Mark Kenney	BSRE/BSCE			X		5
Adam Drotar	BSRE/BSCE				X	50
Luiz Rodriguez	BSRE				X	50
Charles Morton	BSRE				X	100
Chris Leclerc	BSRE				X	50
Joey Yudasz	BSRE			X		5

## **MECHANICAL DESIGN**

EulSpill’s mechanical design focused on dynamic steering capabilities, a low center of gravity, ease of access to each storage compartment and manufacturability.

### **Vehicle Chassis**

The Blue Devil Robotics 2016 IGVC Team focused on designing a lightweight and maneuverable robot platform with a small physical footprint for this year's competition. The chassis was built from square, 1” x 1” aluminum tubing that was cut and welded to design specifications. The aluminum significantly decreased the weight of the robot in comparison to the Blue Devil Robotics 2015 IGVC robot made from steel. Additionally, aluminum’s physical properties eliminate magnetic interference with the IMU sensors. Maneuverability was addressed by designing and building the chassis at the minimum size requirements set by the 2016 IGVC Rules while still maintaining space for all necessary components including the IGVC payload.

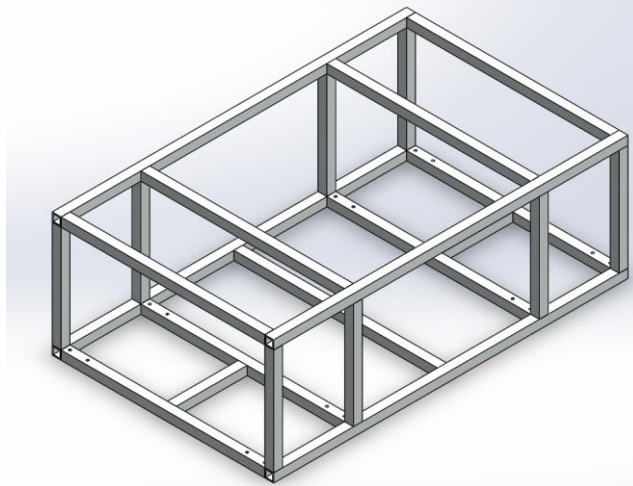
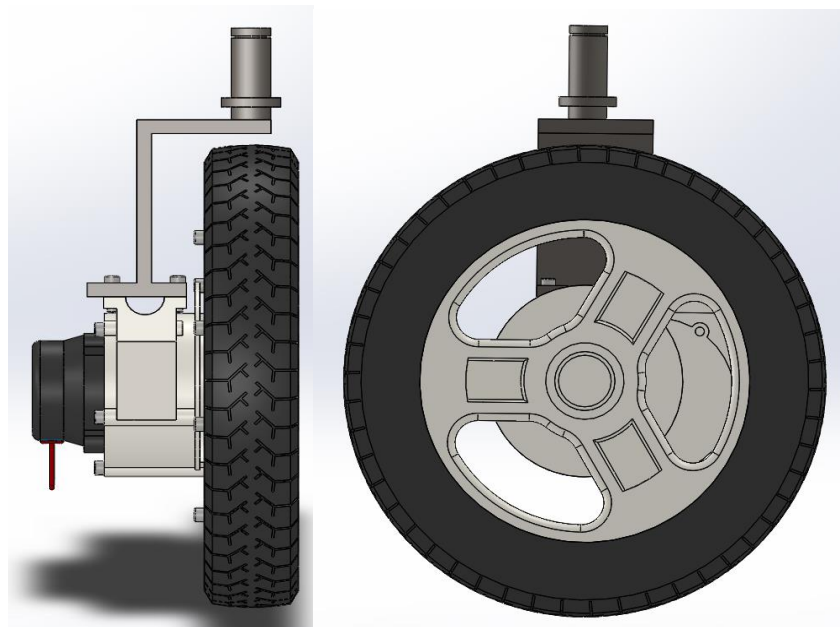

**Figure 3: Isometric View of EulSpill Chassis**

### **Wheel Brackets**

The wheel brackets are an upgrade to the motors used for last year's Blue Devil Robotics 2015 IGVC team. The motor/wheel hubs used on last year's robot did not rotate about the central axis of the wheel. To account for this, brackets were designed and fabricated to set the axis of rotation for each wheel about their central axis.

These brackets were designed and fabricated from steel to provide the strength necessary to withstand the weight of the robot chassis, components and payload. While aluminum would have been a suitable material choice for the brackets, steel was ultimately chosen for its lower cost and the benefit of producing a lower center of gravity for the robot.



**Figure 4: Rear and Side Views of EulSpill Wheel/Motor/Bracket Assembly**

## **Waterproofing**

The robot is designed with waterproofing in mind. The main goal of waterproofing is to account for any possibility of encountering rain over the course of the competition. Weatherstripping covers the perimeter of the robot's roof and all other joints are sealed with caulk. By sealing all joints with caulk, water is not allowed to enter the robot from the roof or the floor and reach any electronic components.

## **MOTORS**

### **Drive Motors**

The drive motors used on this year's robot are the same used by the Blue Devil Robotics 2015 IGVC Team. They are "GoldenMotors" wheelchair motors rated at 24V with a stall current of 80A. The power output of the motors is 250W. In comparison to the motors' performance last year, it is expected that four of them will meet all necessary specifications. Additionally, the motors are mechanically incapable of exceeding the speed requirements set by the IGVC rules due to gearing.

### **Steering Motors**

The steering motors used on this year's robot are the RS775 motors with PG188 Planetary Gearboxes rated at 12V with a stall current of 22A. The gearboxes on these motors are expected to provide sufficient torque to rotate the wheel/motor hub.

## **SENSORS**

The sensors chosen for this system are used to optimize the robot's performance on the Auto-Nav courses. They will allow the robot to perform obstacle detection and avoidance, line detection and following, and GPS waypoint detection and navigation.

### **Cameras**

The camera used on the robot is the Genius 120-degree Ultra Wide Angle Full HD Conference Webcam. The camera will be connected to the onboard computer via USB. A webcam of this type will be placed on each side of the front of the robot facing outward for a wider range of view when detecting lines.

### **LIDAR**

The LIDAR used in this project is the Hokuyo UTM-30LX/LN. It has a scan angle of 270 degrees and a guaranteed maximum read distance of 30 meters. This product far exceeds the distance requirements set by the team. The team only projects scanning a maximum of 5 meters. This gives the vehicle reasonable precision and yet decreases the amount of computation required to extrapolate all the data points.

## **GPS**

The GPS unit used in this project is the GlobalTop FGPMMPA6H. It has an accuracy of 3 meters which is more than the competition requires for waypoint navigation. To overcome this issue, multiple sensors are used together along with a Kalman Filter to predict position.

## **SAFETY ELECTRONICS**

The following components are included in the electrical design with safety as their main function. The stacklight and the E-Stop Button are components required by the official 2016 IGVC Rules.

### **Stacklight**

The stacklight is an upgrade from last year's basic Emergency Light. It utilizes three colors – red, yellow and green. The inspiration behind the stacklight can be found in a majority of robotic manufacturing systems in a number of industries. Besides being used as a warning to persons about the robot, the stacklight also serves as a debugging tool. By having three colors to toggle between, the team can use the stacklight to indicate special events within the software.

At competition, the stacklight's three colors will each represent a state of the robot. A solid green light represents that the robot is in manual mode and is safe to approach. A solid yellow light represents that the robot has had its E-Stop button pressed and that it is approachable, but should be approached with caution. Finally, the red light represents that the robot is in autonomous mode. The red light will only be turned on in a flashing manner as required by the official 2016 IGVC Rules.

### **E-Stop Button**

The E-Stop Button is required by the official 2016 IGVC Rules. The e-stop button on this robot cuts direct power from the Drive System batteries to the rest of the Drive System. This ensures that the robot stops when the button is depressed, but cutting power to only the Drive System does not affect any of the other onboard electrical components.

## **POWER SYSTEM**

The robot is powered by three onboard battery systems. Each system is set apart to power a very specific component or set of components on the robot. This partition was made not only to conserve battery life of certain systems, but also as a safety precaution for more delicate electronics. By removing components such as the onboard computer from the same power system as the steering system, the computer is protected from sudden positive or negative spikes in current caused by the motors.

The power system has been split into three individual power systems: the Drive System, the Steering System and the Computer System.

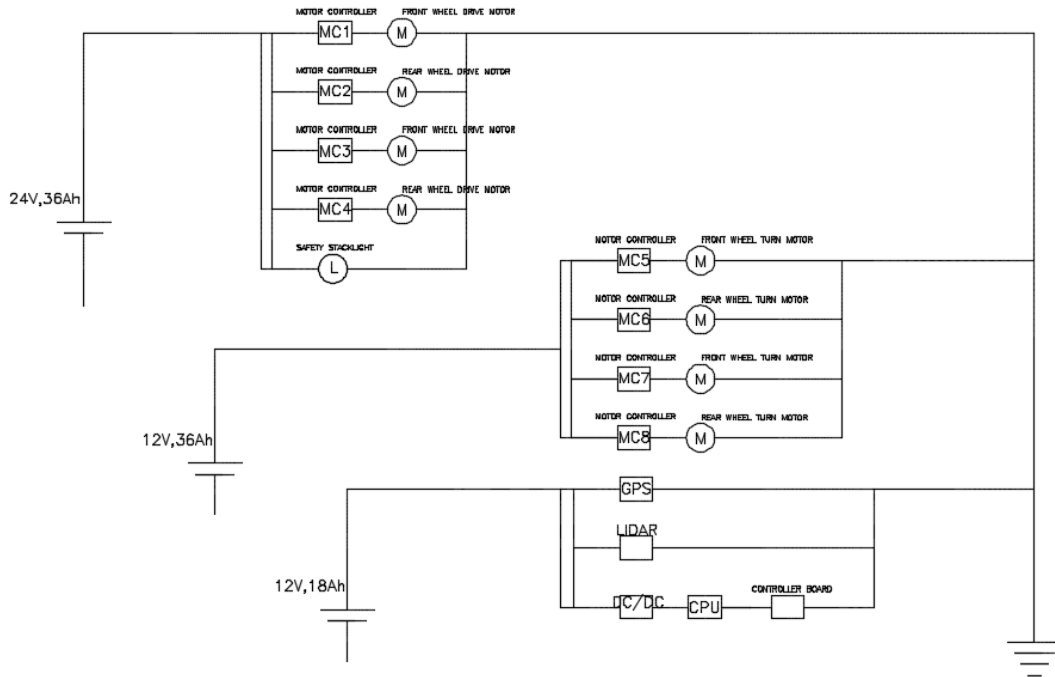

**Figure 5: Power System Diagram**

### Drive System

The main components on the Drive System are the drive motors. Each of the four drive motors requires 24V and an approximated 10A to run for an hour. The drive motors' motor controllers are also on this system in addition to the emergency stacklight. The motor controllers used are Castle Talon 90 motor controllers rated at 6S LiPo and 90A maximum continuous current. The stacklight requires 24V at 5W.

The Drive System is powered by a battery pack rated at 24V, 36Ah. Although one would expect the motors to require more than 36Ah, the distributor of the motors only suggests using a 24V, 10Ah LiFePo4 battery for two motors. Based on the distributor's suggestions, with four motors one should expect that 20Ah would be sufficient. With 36Ah, the Drive System is well supplied.

### Steering System

The main components on the Steering System are the steering motors. Each of the four steering motors requires 24V and 10A to run. The steering motors' motor controllers are also on this system. The motor controllers used are GoolRC motor controllers rated at 16V (max) and 320A.

The Steering System is powered by a battery pack rated at 12V, 36Ah. Based on component specifications, this system will be well supplied.

### Computer System

The main component on the Computer System is the onboard computer. The computer uses a power supply that is designed to run directly from DC power. This allows for the computer to remain on the robot at all times leaving the option to remote access the computer from another system. Its

separation from the Drive and Steering Systems also acts as a safety precaution despite the built-in safety components of the power supply.

The Computer System is powered by a battery pack rated at 12V, 18Ah. Based on component specifications, this system will be well supplied.

## **MAPPING TECHNIQUES**

There are two separate systems for collecting data from the surrounding environment, the vision and the LIDAR system. The vision system consists of two cameras, they are used to detect lines and “pot holes” (White spots) painted in the grass. The LIDAR is used to detect obstacles and walls/fences. The information gathered from these two systems are sent to a single map that the vehicle's path finding algorithm runs.

The dual webcams are used to retrieve a wider angle of view than a single webcam. There is no need to stitch the image or create a depth map since the LIDAR collects depth information. Each image from the webcam is transformed to create a 2D perspective in real world coordinates. Once this calibration is done, each pixel can be mapped linearly to a distance. Each pixel that is found to be a part of a line will be mapped on a local map of the environment. The LIDAR output is much easier to map, there is no need for filtering. Using trigonometry, each data point can be mapped on the local map.

To create an absolute map of the environment, the vehicle must know its position and orientation in space. Using GPS, accelerometer, gyroscope, and magnetometer, a position can be estimated using a Kalman filter. Once either system, Camera or LIDAR, detects a point, whether is it from a line in the grass or barrel in front of the robot, it is plotted on the local map. The local map is then added to the absolute map once the position and orientation of the vehicle is known. The position and orientation may shift, therefore, points will also shift. To fix this issue, any point that is found and is not on the map, it is plotted. If there is a point on the map and is not found, then that point is deleted.

## **SOFTWARE STRATEGY**

The camera feed and LIDAR data are used for obstacle detection while the GPS and IMU are used for position data. Figure 6 shows the entire structure of the software process.

## **SYSTEM INTEGRATION**

The vehicle must have three systems to successfully navigate through a course: waypoint navigation, lane following, and obstacle detection/avoidance systems. The waypoint navigation system uses an IMU to calculate its position and navigates through each waypoint. Lane following system determines the direction the vehicle must be heading and the boundary in which it must operate. Obstacle detection/avoidance system is used to navigate between lines to ensure obstacles are avoided in a reasonable manner.

These systems were integrated using a single module (IO\_Manager) that collects all incoming data and transmits all outgoing data to appropriate systems. These systems may just be used to calculate



position within the program, eventually being sent back to the IO\_Manager, or actual subsystems like motor controllers.

### Waypoint Navigation

To get an accurate real world position, the GPS is used in conjunction with a magnetometer, gyroscope, and accelerometer. These extra modules are used in a multi-dimensional Kalman filter to achieve an accurate estimation of the real world position.

The vehicle is judged based on the time it takes to get through the course therefore the shortest path between each waypoint should be used. The waypoints are treated as nodes in a graph, with each have a path to another. Using Dijkstra’s algorithm, the shortest route can be determined ensuring all the GPS waypoints are hit. The order in which the waypoints will be navigated is determined prior to the robot running through course. The route is planned immediately once the GPS points are loaded into the system.

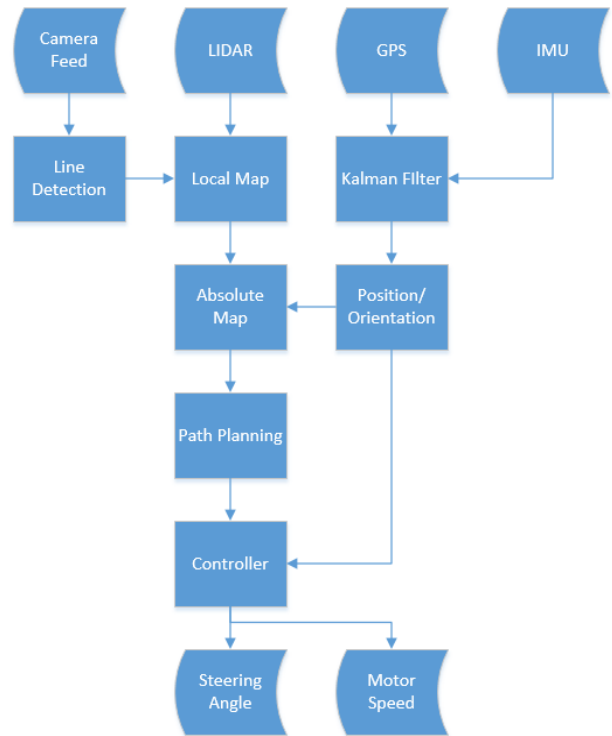

**Figure 6: Program Flowchart**

### Lane Following

In order for accurate lane following, lines must first be detecting in the grass. Last year we ran filters over the webcam image in HSV spectrum to help distinguish the white lines in the green grass. This worked rather well but the lines were noisy and did not work well with our A\* path finding algorithm. Instead of looking at each individual pixel and determining if it was part of a line, this year the convolution of the image was created using a unique kernel that subtracts all the surrounding pixels by the selected pixel. After running a threshold filter over the image a pure black and white image is created, the white pixels are then plotted onto the local map as discussed under mapping techniques.



**Figure 7: White line in grass after Convolution**

## Obstacle Detection/Avoidance Systems

The path finding algorithm uses an absolute map that has been generated using the vehicle's IMU and a local map. Using the mapping techniques discussed in previous sections, lines and barrels are treated as impassable objects. The algorithm will generate a path forward, once a new obstacle is detected, whether it is a line or barrel, the algorithm will generate a new path around the object.

The pathing algorithm will use a D\* path algorithm, similar to last years A\* path algorithm. The D\* algorithm is more efficient than the A\* algorithm because it does not compute the entire trajectory every time. The D\* algorithm only updates itself when an obstacle is detected along the current path and updates all points affected. Teams in the past have used this algorithm with much success.

## BUDGET

In comparison to the Blue Devil Robotics 2015 IGVC Team, the 2016 team was able to earn many valuable industry sponsorships. The most notable donations came from Jacobs Engineering and Ford Motor Company.

DATE:	BUDGET:	EXCHANGE/DESCRIPTION:					
1/26/2016	\$1,055.35	-\$86.95 iTuner	-\$309.97	Amazon	-\$66.86	Amazon	
	\$591.57						
3/29/2016	\$591.57	\$3,000 Jacobs Engineering					
	\$3,591.57						
4/6/2016	\$3,591.57	-\$101.95 CPU	-\$349.31	CHASSIS	-\$72.74	CHASSIS	-\$392.46 CPU
	\$2,675.11						
4/18/2016	\$2,675.11	-\$217.10 Electronics (Amazon)					
	\$2,458.01						
	\$2,458.01	-\$325 ESCs (Nankin Hobby)					
	\$2,133.01						
	\$2,133.01	-\$141.03 Misc. (McMaster)					
	\$1,991.98						

Figure 8: Budget Description

## CONCLUSION

EulSpill's design drew upon Blue Devil Robotics 2015 IGVC experiences. The chassis was designed to be lighter and simpler to fabricate and assemble. The drivetrain grants the robot superior maneuverability to avoid obstacles. The software was constructed in a way to maintain a level of abstraction, allowing the programming team to collaborate with ease. The Blue Devil Robotics 2016 IGVC Team is looking forward to the 2016 IGVC with great pride in their work and anticipation to put it to the test.

## REFERENCES

1. Choudhari, Dilip S. Research Paper FOUR WHEEL STEERING SYSTEM FOR FUTURE (n.d.): n. pag. Web.
2. Gudhka, Vatsal, Saket Bhishikar, Paarth Mehta, Neel Dalal, and Sunil Bhil. "Design and Simulation of 4 Wheel Steering System." International Journal of Engineering and Innovative Technology (IJEIT) (n.d.): n. pag. Web.
3. *IGVC Website*. Oakland University, 2015. Web. 25 March 2015.
4. Morsche, M.H. Te. "Design of an Independent Front Wheel Steering System with Optimal Driver Feedback." TU Delft. N.p., n.d. Web.
5. "Wire Gauge and Current Limits Including Skin Depth and Strength." American Wire Gauge Table and AWG Electrical Current Load Limits with Skin Depth Frequencies and Wire Breaking Strength. N.p., 09 Mar. 2016. Web. 15 May 2016.
6. Wu, Xiaodong, Min Xu, and Lei Wang. "Differential Speed Steering Control for Four-Wheel Independent Driving Electric Vehicle." International Journal of Materials, Mechanics and Manufacturing IJMMM (2013): 355-59. Web.

May 12, 2015

re: Lawrence Technological University entry EulSpill

As advisor to the 2016 Lawrence Tech EulSpill IGVC team, I am pleased to certify that the design and engineering of this new vehicle by the current student team is significant and equivalent to what has been awarded credit as their senior capstone design course.



Prof. Jim Kerns  
Robotics Laboratory Instructor  
A. Leon Linton Department of Mechanical Engineering  
Lawrence Technological University  
21000 W. Ten Mile Rd.  
Southfield, Michigan 48075  
Tel: (248) 204-2512  
E-mail: [jkerns@ltu.edu](mailto:jkerns@ltu.edu)